



# GRYF

Manufacturer of Measuring Instruments

## Instruction and Maintenance Manual

### CO and CO<sub>2</sub> Measuring

#### Contact

**GRYF HB, spol. s r.o.**

Cechova 314

Havlickuv Brod

580 01

tel.: +420 569 426 627

fax: +420 569 426 627

Czech Republic

[www.gryf.eu](http://www.gryf.eu)





# GRYF

Manufacturer of Measuring Instruments

## CO a CO2 Measuring Instrument

### Basic description:

This measuring system utilizes a universal instrument GRYF 9605 (unimeter) to measure CO and CO<sub>2</sub> in gases. The system is also equipped with power circuits and everything (with the exception of the sensors) is located in a box with IP 67 coverage. Outside this box is a base plate containing the following: Measuring cells with sensors and a regulation valve. This valve is set to 1 bar.

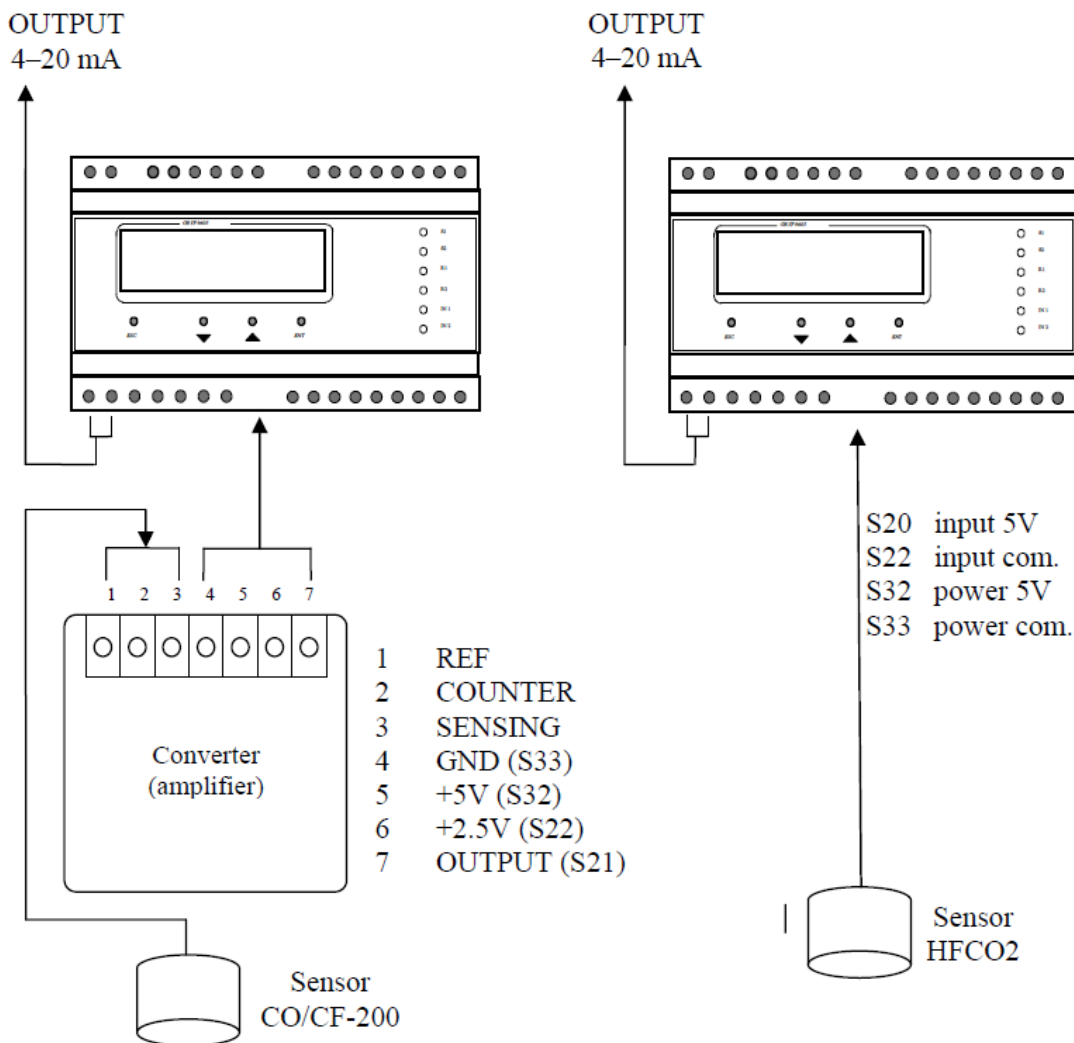



# GRYF

Manufacturer of Measuring Instruments

## Measuring CO:

A CO/CF-200 sensor is used to measure CO concentrations. Its detailed description can be found in a separate document. This is an electrochemical sensor with three electrodes: Sensing, Counter and Reference. This sensor is connected to an amplifier/converter which modifies the signal for the GRYF 9605 instrument. The CO measuring range is 0-65.0ppm. The outcome measurement is displayed on GRYF 9605 and current loop 4-20mA.

4mA ... 0.0 ppm  
20mA ... 65.0 ppm

Setting the GRYF 9605 instrument:

The following settings can be found in the **SET3** menu:

Parameter number	Parameter name	Parameter value	
0	Measuring range	2	1V
1	Upper limit	650	
2	Decimal point	65.0	
3	Output	1	unipolar

Sensor Lifetime ... 2-3 years  
Calibration Cycle ... 6 month  
Recommended calibration gas (zero point) ... Nitrogen 6.0  
Recommended calibration gas (slope) ... 40 ppm CO

## Measuring CO2:

An HFCO2 sensor is used to measure CO2 concentrations. Its detailed description can be found in a separate document. This is an infrared sensor (NDIR). The sensor is connected directly to the GRYF 9605 instrument. The CO2 measuring range is 0-500ppm. The outcome measurement is displayed on GRYF 9605 and current loop 4-20mA

4mA ... 0 ppm  
10.4mA ... 500 ppm (max. measurable value)  
20mA ... 1250 ppm (only a theoretical output value)

## Setting the GRYF 9605 instrument:

The following settings can be found in the **SET3** menu:

Parameter number	Parameter name	Parameter value	
0	Measuring range	1	5V
1	Upper limit	1250	
2	Decimal point	1250	
3	Output	1	unipolar



# GRYF

Manufacturer of Measuring Instruments

Sensor Lifetime	... 5 years
Calibration Cycle	... 6 month
Recommended calibration gas (zero point)	... Nitrogen 6.0
Recommended calibration gas (slope)	... 400 ppm CO <sub>2</sub>

## GRYF 9605

### Stationary Uni-meter – temperature meter

#### Basic Description

GRYF 9605 is a microprocessor controlled instrument intended for industrial measuring of electrical voltage and current with capability to transfer data through a current output. Any type of a sensor or an electrode which has a defined voltage or current output can be used with the Gryf 9605. This unit is designed as a module and is mounted on a DIN 35 rail. Its housing only provides basic protection. Greater protection can be obtained by securing the unit inside an appropriate box or case.

Basic Technical Parameter	
Uni-meter measuring ranges	±10V, ±5V, ±1V, ±300mV, ±70mV, ±20mA, 4-20mA, ±5mA
Uni-meter measuring accuracy	0.05 %, ±1 dig.
Temperature measuring range	-50 ÷ 200 °C
Temperature measuring accuracy	± 0,2 °C, ± 1 dig.
Input voltage resistance	1MΩ
Input current resistance	100Ω
Temperature sensor	Ni 1000 6180 ppm
Power supply	12 ÷ 35 V DC, 12 ÷ 24 V AC
Power consumption (dependent on the equipment)	max. 3 W
Current drain from rectifier terminals (S30,S31)	max. 200 mA
Internal current drain 5V (S32,S33)	max. 100 mA
Electronic switches (Logical outputs)	28V, 100mA DC
Logical inputs – input voltage for logic one	5 ÷ 35V DC, 11 ÷ 60V AC
Logical inputs – internal resistance	500 Ω
Operating temperature range	0 °C ÷ 50 °C
Storage temperatures	-20 °C ... 80 °C
Unit size	105 x 57 mm



# GRYF

Manufacturer of Measuring Instruments

Current Output	
Voltage availability	8 V
Maximal loop resistance	400 $\Omega$
Max. transfer non-linearity of current loop driver	0,10%
Current range	4 $\div$ 20 mA

## Functions

This instrument carries out measurements twice per second. Measured voltage or current value is displayed on a LED display. Temperature value can also be displayed on the LED display. Electronic switches are set depending on the Uni-meter information (if equipped with PI regulator, current output or an RS-485 communication line).

**The Meter is controlled by four keys whose functions are as follows:**

- ESC**      escape a selected mode
- ↑,↓**      selecting a function, adjusting values
- ENT**      enter a selected mode, switching between the main value and temperature

## Main Menu

**The main menu contains the following entries:**

- **CAL**      (Uni-meter calibration)
- **SET 1**      (setting of logical outputs – electronic switches)
- **SET 2**      (PI controller setting)
- **SET 3**      (Uni-meter parameter adjustment)

By pressing the ESC button, you can leave the main menu and re-enter to the measuring mode. It is important to note that while the unit is in any of the main menu modes, its measurement functions nor its adjustments of the logical outputs or PI controller, etc. do not operate. The unit memorizes the previous state of these outputs until it is switched to the measurement mode again by pressing ESC.



# GRYF

Manufacturer of Measuring Instruments

## Measuring electrical voltage & current and temperature

Terminals for measuring electrical voltage and current are galvanically separated from the input supply voltage and other terminals, however, not from the internal power supply 5V (S32, S33) and between each-other. After connecting the supply voltage, the instrument is ready to start taking measurements. The display will show the measured value of the Uni-meter. Measuring takes place according to the range selected. This range can be selected in the main menu SET3. Here you can also choose how the measured data should be displayed. The ENT button will allow the user to switch from displaying the temperature value (t mark will appear on the left side) and the current & voltage value. While viewing the main value, by pressing the ESC button, the instrument will display the main menu. Should any of the values being measured exceed the given parameters, the following reports will appear:

**Err** - electrical current or voltage exceeded the maximum parameter selected.

**-Err** - electrical current or voltage exceeded the minimum parameter selected.

**-tErr** - temperature is out of range (-50 - +200°C) or the temperature sensor is disconnected.

As stated above, the logical outputs and other output values are set in relation to the measured value. The instrument is equipped with logical inputs with which some outputs can be deactivated.

LI1 S13, S14 - After applying voltage to this input, both electronic switches will be disconnected or switched off and the indicator lamp IN1 will turn on.



# GRYF

Manufacturer of Measuring Instruments

## Uni-meter Parameter Adjustment

Uni-meters parameters can be adjusted in the main menu "SET3". This feature can be activated only with the simultaneous activation of the magnetic switch on the left side of the instrument. This will allow the user to set the high limit of the values being measured (see picture below). Furthermore, it is possible to choose the method of how the current loop or the RS485 will be conducted. Bi-polar or Uni-polar regime can be chosen. During the Bi-polar regime, both positive and negative values will be transmitted. During the Unipolar regime, only positive values will be transmitted

Item "1" changes the calibration constant of the Uni-meter. If item "1" is confirmed by pressing the ENT button, new values will be added to the calibration constant. This is why we do not recommend using the menu "SET3" and if menu "SET3" is used, it is recommended to perform calibration.

SET 3			
0	Measuring range	0	$\pm 10V$
		1	$\pm 5V$
		2	$\pm 1V$
		3	$\pm 300mV$
		4	$\pm 70mV$
		5	$\pm 20mA$
		6	4 - 20mA ( $\pm 16mA$ and move zero to 4mA)
		7	$\pm 5mA$
1	Value of high range XXX		0 ÷ 9999
2	Location of decimal point		9999 999,9 99,99 9,999
3	Output bi-polar / uni-polar	0	Bi-polar
		1	Uni-polar

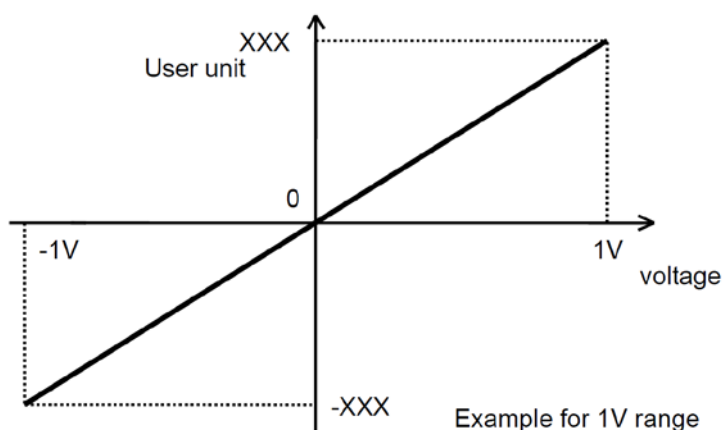



# GRYF

Manufacturer of Measuring Instruments

## Uni-meter Calibration

Calibration is performed in two stages. Zero point and slope are calibrated. Calibration can be performed in the main menu (by pressing "ESC") under "CAL". After Calibration has been chosen, "C-S" (slope) will appear on the display. After pressing ENT button, sheerness can be calibrated. Pressing the ESC button will return you to the measuring mode. Pressing the ↓ button allows to calibrate the zero point "C - 0" will appear on the display (zero point). This part of the calibration can be skipped by pressing "ESC".

By pressing ENT a measured value will appear on the display (just as in the measuring mode). The ↑, ↓ buttons are used to adjust the zero point (change of the calibration constant of zero point). Calibration is performed by connecting the appropriate input terminals. Using the ↑, ↓ buttons, the value is set to zero. To return to measuring mode, press "ESC".

The same procedure as above applies for sheerness calibration. The ↑, ↓ buttons are used to adjust the sheerness (change of the calibration constant). Calibration is performed by connecting a known voltage to a selected input terminal. The ↑, ↓ buttons are used to adjust the measured value on the display to match the power input. To return to measuring mode, press "ESC".

## Current Output

If the meter is equipped with a current loop (line), the user has the possibility to transfer measured values by means of an analog signal of 4 to 20 mA DC. The current is supplied to the closed circuit from its own module and does not require a special power supply. Current loop terminals are galvanically separated from all the other terminals. Thus the power of resistance to the interference is considerably increased and the rise of parasitic loops is prevented. Loop interruption is signaled by a pilot lamp placed near the S1 terminal and at the same time by switching the electronic switch (S1, S2 terminals). This electronic switch has the same parameters as the logical outputs.

Current loop calibration is performed by the manufacturer and is carried out by resistance trimmers placed between the S1 and S2 terminals. A trimer which is found closer to the edge of the circuit board serves to adjust the slope, while the other one is used for the zero adjustment.

4 mA ..... 0  
20 mA ..... upper range limit





# GRYF

Manufacturer of Measuring Instruments

## Attachment

The unit is designed to be mounted on a DIN 35 rail. Its housing provides only basic protection. Greater protection can be obtained by securing the unit inside an appropriate box or case.

## Power Supply to the Uni-Meter – Temperature Meter

The meter can be powered by AC or DC voltage according to the specifications. If the unit is powered by AC voltage, its frequency cannot exceed 200 Hz. The power input circuit features a filter which reduces interference from the power supply. All terminals of the meter are galvanically separated from the power terminals except for the S30, S31.

## Measured Signal to the Uni-Meter

Instrument is equipped with 3 voltage inputs and 1 current input. Its important to use the appropriate input according to the chosen parameters. Terminal S22 (GND-U) is intended for a shield connection. Inputs are described in the following chart.

## Mechanical Configuration

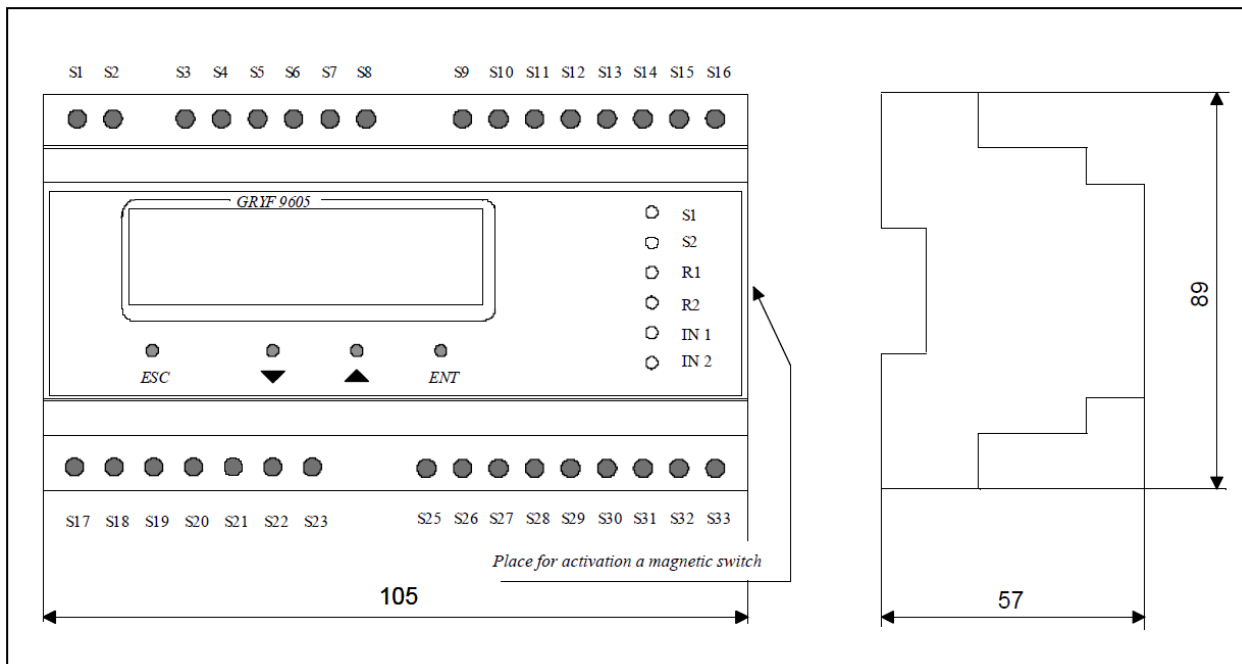



# GRYF

Manufacturer of Measuring Instruments

## Terminal Specifications

S1	Error + (disconnect current output)
S2	Error - (disconnect current output)
S3	
S4	
S5	
S6	
S7	switch 1 – positive terminal
S8	switch 1 – negative terminal
S9	switch 2 – positive terminal
S10	switch 2 – negative terminal
S11	LI 2 Logical Input – positive terminal
S12	LI 2 Logical Input – negative terminal
S13	LI 1 Logical Input – positive terminal
S14	LI 1 Logical Input – negative terminal
S15	Power supply
S16	Power supply
S17	Current output (+)
S18	Current output (-)
S19	Input 10V
S20	Input 5V, 300mV
S21	Input 1V, 70mV
S22	Input common
S23	Input 20mA, 5mA
S25	Temperature sensor - NS26
S26	Temperature sensor - TS27
S27	Temperature sensor - shield (GND-T)
S28	Temperature sensor - T+
S29	Temperature sensor - N+
S30	Rectified voltage from S15, S16 positive terminal
S31	Rectified voltage from S15, S16 negative terminal
S32	Inner 5V power supply – positive terminal
S33	Inner 5V power supply – negative terminal (GND)



# GRYF

Producer of Measuring Instruments

**GRYF HB, spol. s r. o.**

Čechova 314

580 01 Havlíčkův Brod

Česká republika

[gryf@gryf.eu](mailto:gryf@gryf.eu)

Tel./Fax: 00 420 569 425 024

[www.gryf.eu](http://www.gryf.eu)

